

Bridge 467.8 Replacement

Project Description

The Alaska Railroad Corporation (ARRC) will replace the seven-span 98-foot timber trestle bridge that crosses a drainage flow at ARRC milepost 467.8, just south of the Fairbanks Rail Yard. The project will replace the bridge with three 48-inch diameter, 68-foot long smooth steel pipe culverts, with riprap armoring and guide banks.

Purpose and Need

The culverts will replace an aging timber bridge that is reaching the end of its useful life span. Bridge replacement will help ensure railroad infrastructure remains in a state of good repair. The integrity of bridge infrastructure ensures the safety and reliability of rail operations to meet business demands. General bridge rehabilitation benefits are outlined in the current Bridge Program fact sheet.

Status

- Preliminary project studies, environmental reviews, design and permitting began in fall 2021.
- The project is 30% designed. Final (60-100%) engineering/design will be complete by fall 2023.
- The project team prepared Categorical Exclusion (CE) environmental review documentation to meet National Environmental Policy Act (NEPA) requirements. The CE has been submitted to the Federal Transit Administration (FTA) for review.
- The construction contract is expected to be bid during the second quarter of 2023, with a contractor selected shortly thereafter.
- Construction is scheduled to begin third quarter of 2023, continuing into first quarter of 2024.
- Project completion is estimated by the end of the second quarter of 2024.



Bridge 467.8 crosses an unnamed drainage flow just south of the Fairbanks Rail Yard.

Project Area - Bridge MP 467.8, Side View

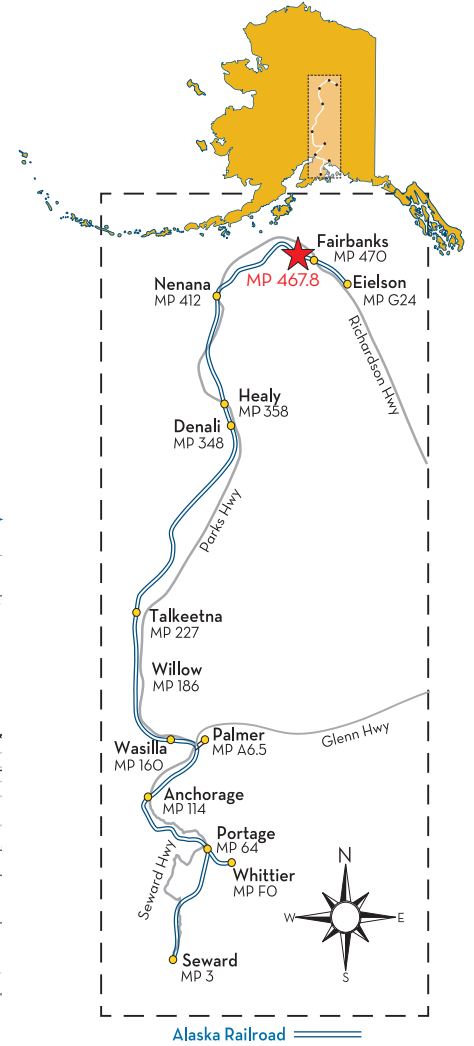
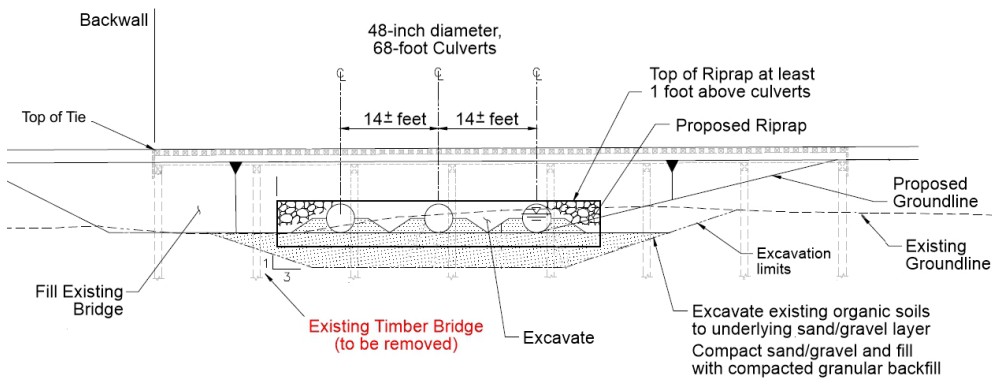

Project Area - Bridge MP 467.8, Top View

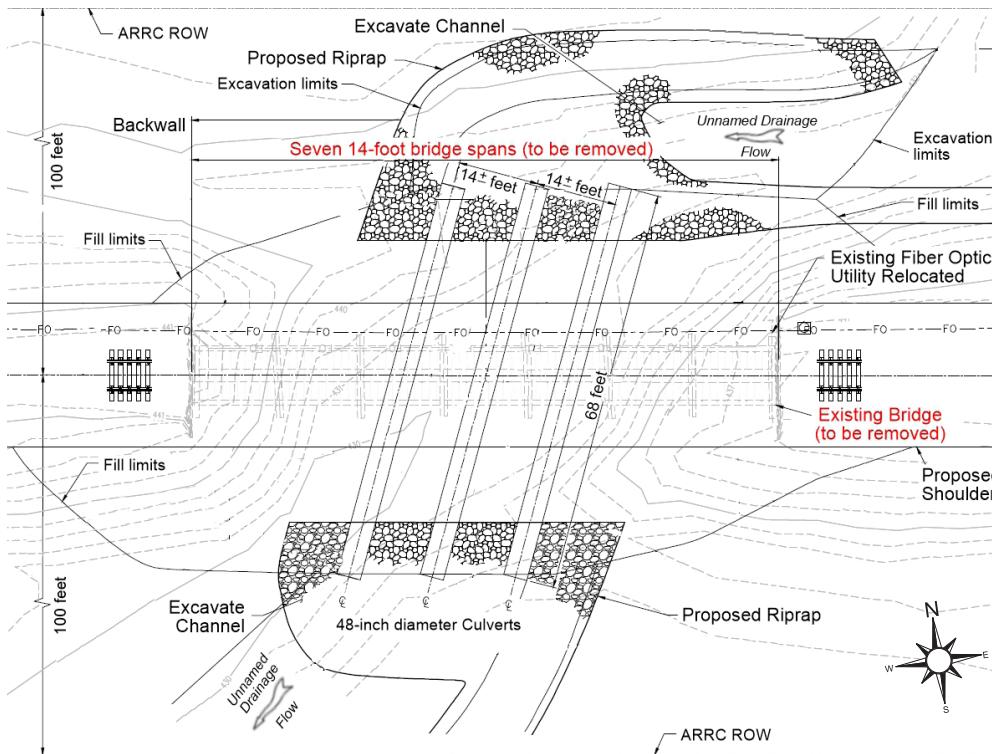

Project work will include full replacement of the existing bridge with three culverts.

Cost and Funding

The project budget is approximately \$1.03 million. Funding is 80% from the FTA, with a 20% match from ARRC.

More Information

For more project information, email the Alaska Railroad at Public_Comment@akrr.com. The ARRC Bridge Program fact sheet is available online at AlaskaRailroad.com > Corporate > Projects (look under *Systemwide Projects*).