

ARR 301 SINGLE SEAT FRAME BOM		
ITEM	QTY	DESCRIPTION
1	1	1"x0.0625" A36 MILD STEEL TUBE, 10.75" LONG
2	1	0.25" x 1.5" 1018 CARBON STEEL BAR, 20" LONG, SEE SHEET 2
3	1	1"x0.0625" A36 MILD STEEL TUBE, SEE SHEET 2
4	1	1"x0.0625" A36 MILD STEEL TUBE, 41.31" LONG, SEE SHEET 2
5	1	0.25" 1018 CARBON STEEL PLATE, SEE SHEET 2
6	4	1"x0.0625" A36 MILD STEEL TUBE, 39.31" LONG
7	2	1"x0.0625" A36 MILD STEEL TUBE, SEE SHEET 2
8	2	1"x0.0625" A36 MILD STEEL TUBE, SEE SHEET 2
9	2	1"x0.0625" A36 MILD STEEL TUBE, 25.75" LONG
10	1	1"x0.0625" A36 MILD STEEL TUBE, 39.31" LONG, SEE SHEET 2
11	1	1"x0.0625" A36 MILD STEEL TUBE, 41.31" LONG

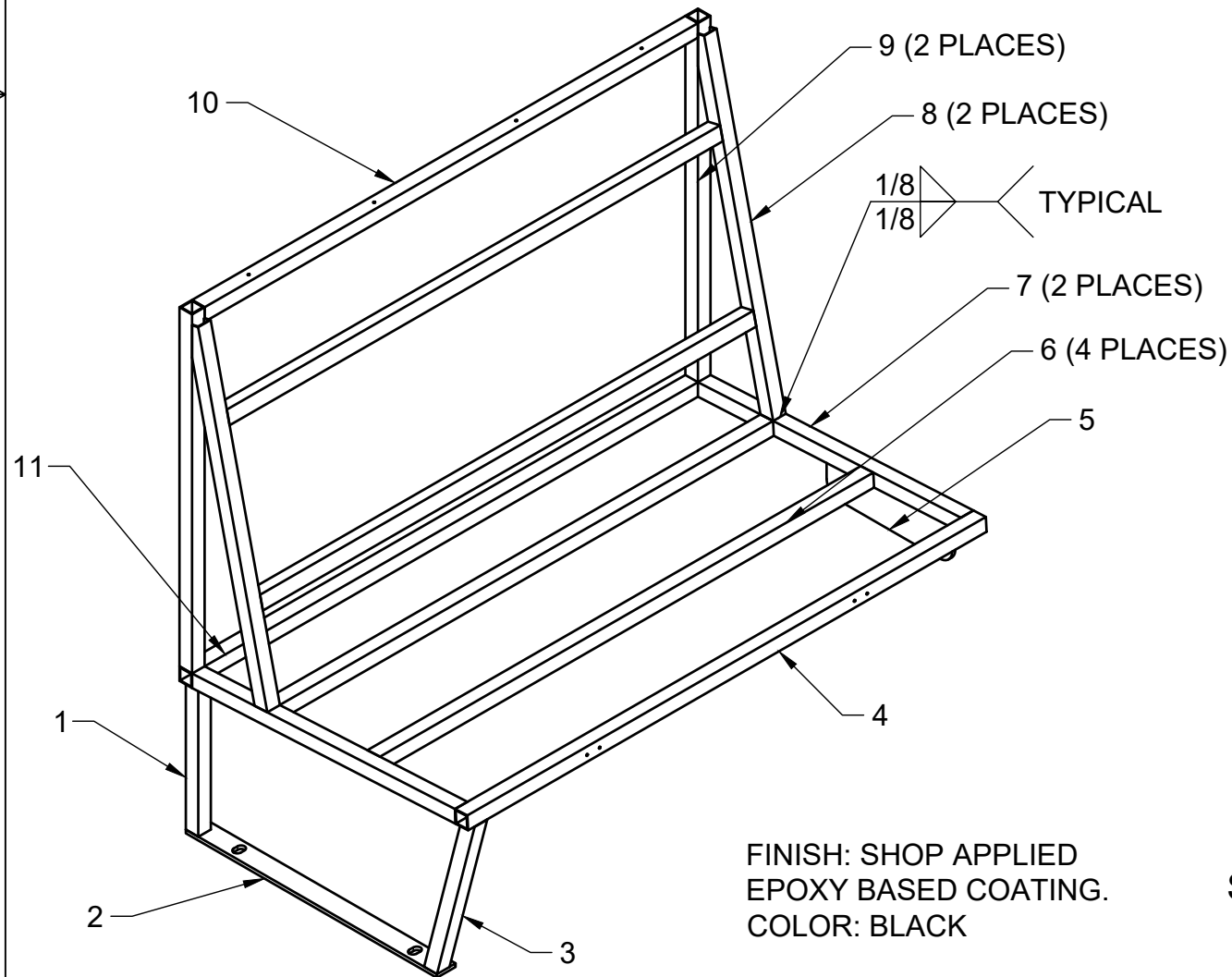

FINISH: SHOP APPLIED
EPOXY BASED COATING.
COLOR: BLACK

NOTE:
RIGHT HAND SINGLE SEAT
FRAME SHOWN, LEFT HAND
IS MIRROR IMAGE.

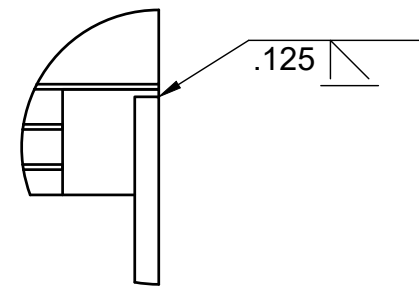

DETAIL A
SCALE 1:2

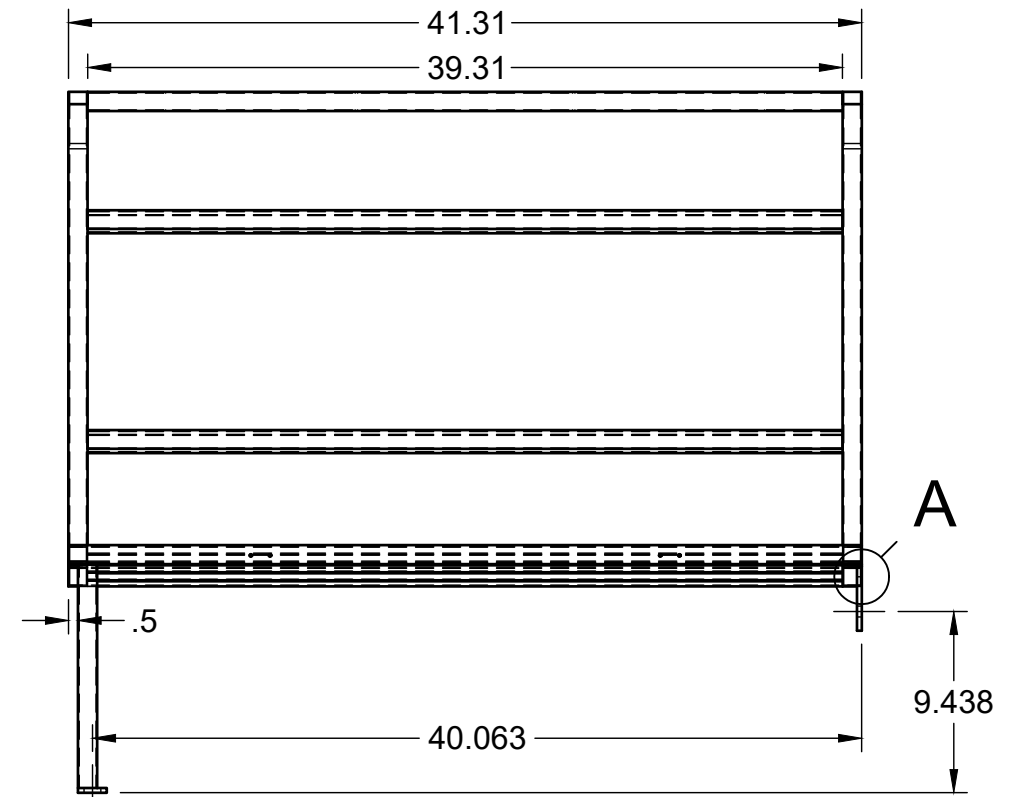

<p>ALASKA RAILROAD CORPORATION ENGINEERING SERVICES</p>	PROJECT		MOTIVE POWER AND EQUIPMENT PASSENGER COACHES	
	TITLE			ARR 301 SINGLE SEAT FRAME FRAME ASSEMBLY
	APPROVED ARRC	SCALE 1:10	SHEET 1/4	
	CHECKED ARRC	DATE 9/13/2022		
DRAWN CDL				

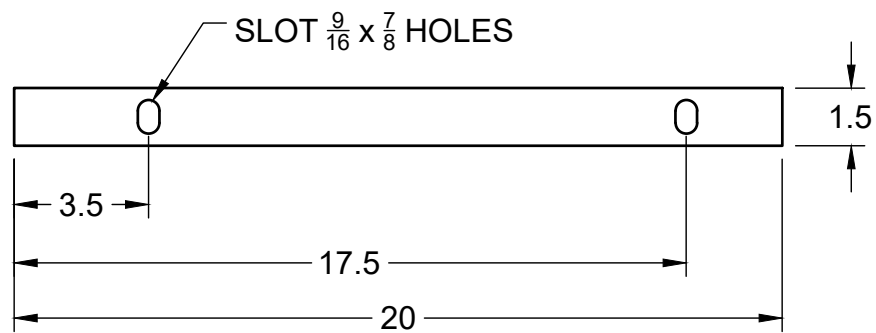

ITEM 2 - TOP VIEW

FROM SHEET: 1
MATERIAL: 0.25" x 1.5" 1018 CARBON STEEL BAR

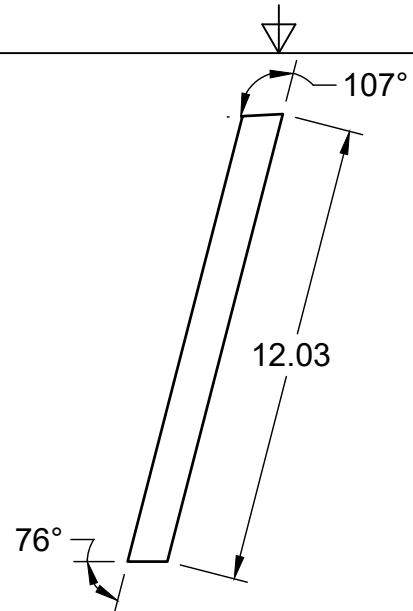

ITEM 3 - TOP VIEW

FROM SHEET: 1
MATERIAL: 1"x0.0625" A36 MILD STEEL TUBE

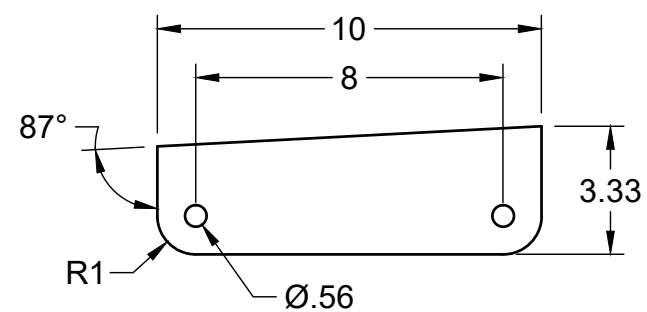

ITEM 5 - SIDE VIEW

FROM SHEET: 1
MATERIAL: 0.25" 1018 CARBON STEEL PLATE

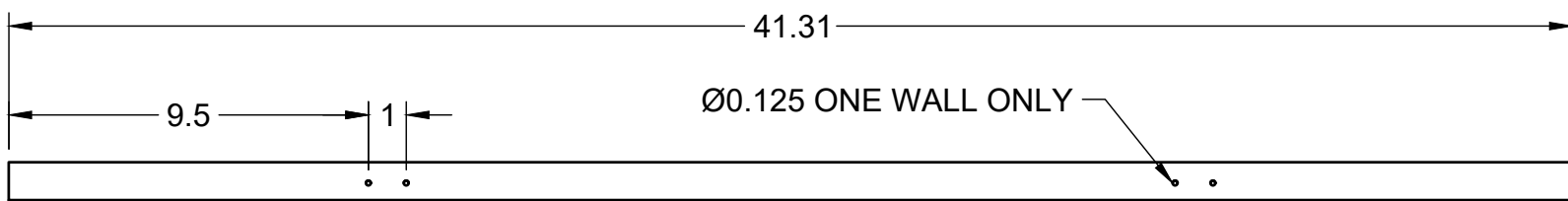

ITEM 4 - TOP VIEW

FROM SHEET: 1
MATERIAL: 1"x0.0625" A36 MILD STEEL TUBE

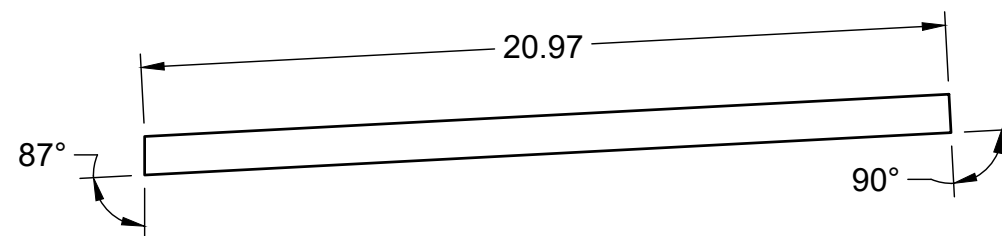

ITEM 7 - SIDE VIEW

FROM SHEET: 1
MATERIAL: 1"x0.0625" A36 MILD STEEL TUBE

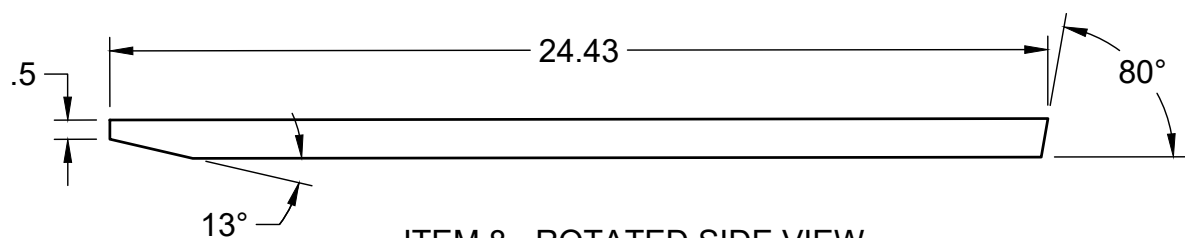

ITEM 8 - ROTATED SIDE VIEW

FROM SHEET: 1
MATERIAL: 1"x0.0625" A36 MILD STEEL TUBE

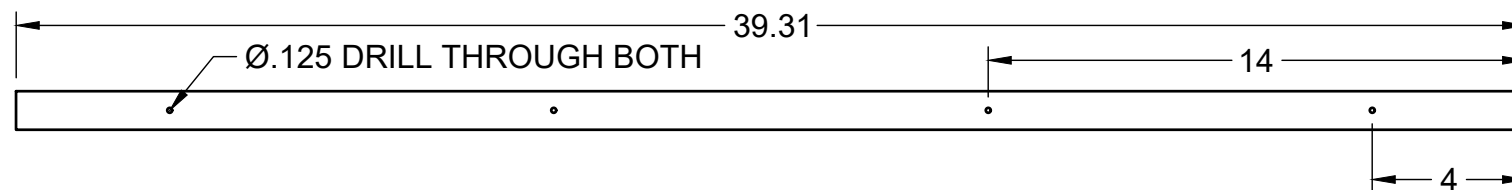

ITEM 10 - ROTATED SIDE VIEW

FROM SHEET: 1
MATERIAL: 1"x0.0625" A36 MILD STEEL TUBE



ALASKA RAILROAD
CORPORATION
ENGINEERING SERVICES

PROJECT
MOTIVE POWER AND EQUIPMENT
PASSENGER COACHES

TITLE
ARR 301 SINGLE SEAT FRAME
ITEM FABRICATION DETAILS

APPROVED ARRC
CHECKED ARRC
DRAWN CDL

SCALE 1:5

DATE 9/13/2022

SHEET 2/4

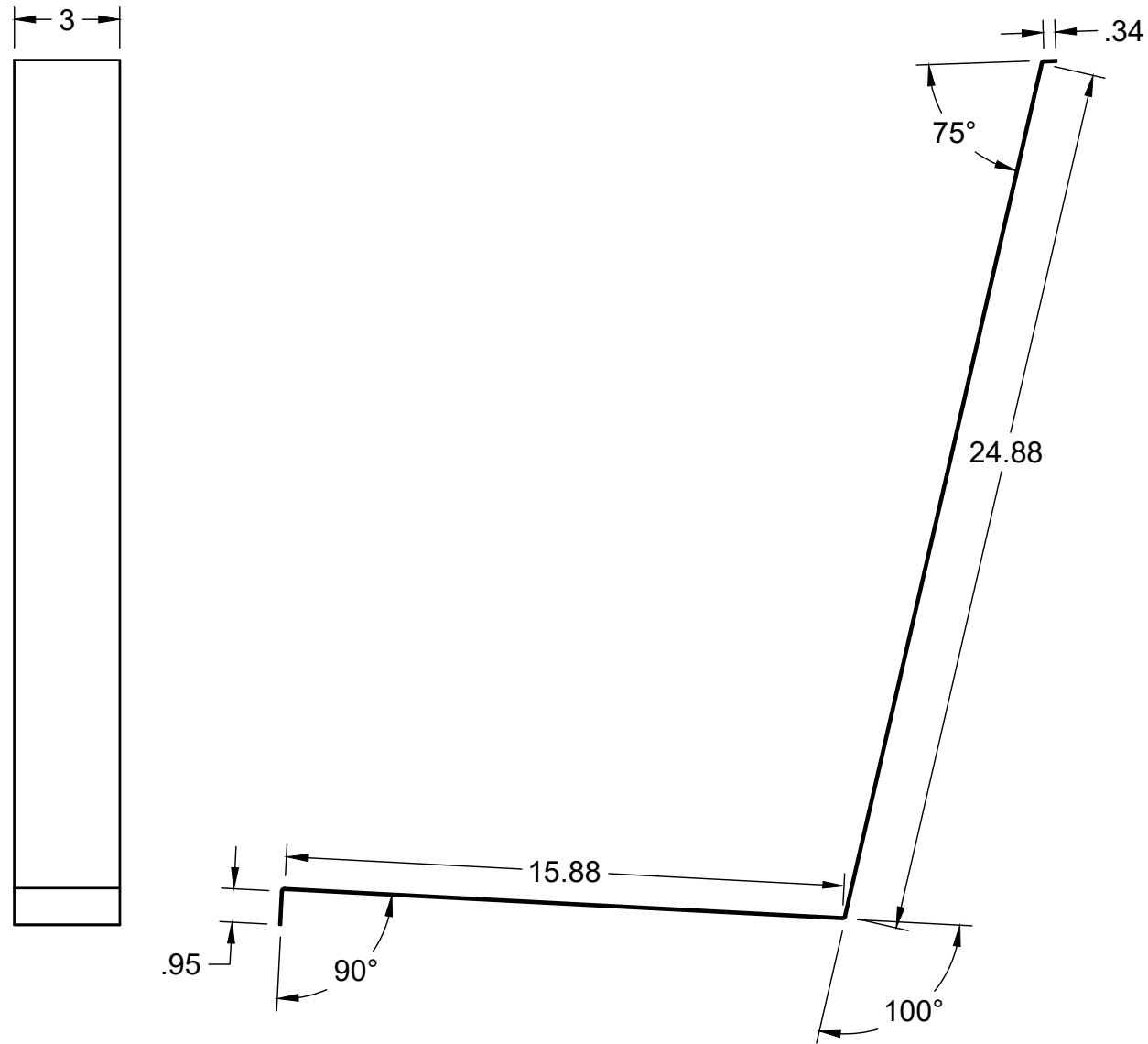

FRAME EDGE TRIM

MATERIAL: 18GA 304 SS #4 BRUSH FINISH
 PN ARR-301-0001
 SEE DXF FILE FOR FLAT PATTERN SHAPE
 QTY (1) PER ASSEMBLY

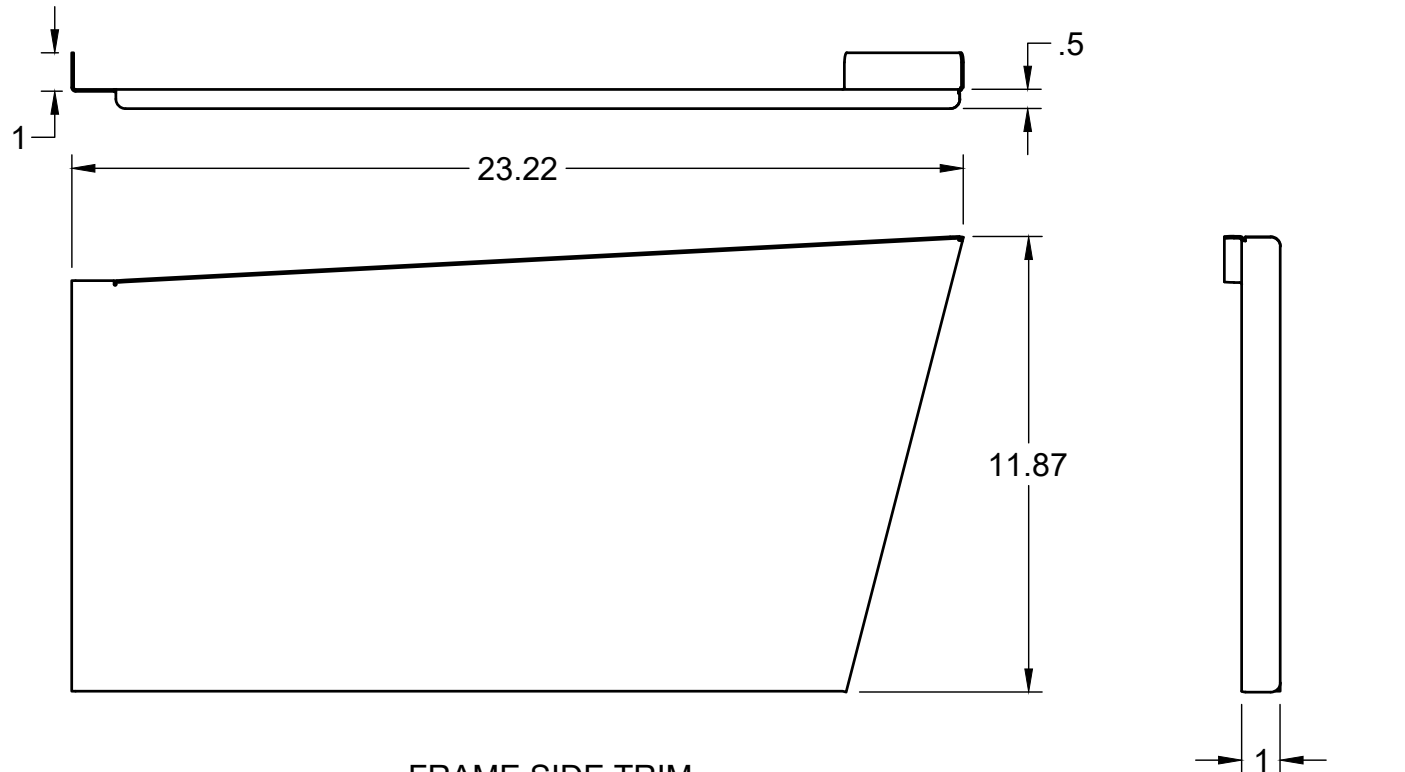

FRAME SIDE TRIM

MATERIAL: 18GA 304 SS #4 BRUSH FINISH
 PN ARR-301-0002
 SEE DXF FILE FOR FLAT PATTERN SHAPE
 QTY (1) PER ASSEMBLY

NOTE: PN ARR-301-0005 'SINGLE SEAT FRAME
 LEFT SIDE TRIM' IS MIRROR IMAGE OF RIGHT
 SIDE TRIM.

 ALASKA RAILROAD CORPORATION ENGINEERING SERVICES	PROJECT MOTIVE POWER AND EQUIPMENT PASSENGER COACHES		
	TITLE ARR 301 SINGLE SEAT FRAME TRIM PARTS		
	APPROVED ARRC	SCALE 1:5	SHEET 3/4
	CHECKED ARRC	DATE 9/13/2022	
DRAWN CDL			



REVISION HISTORY			
REV	DESCRIPTION	DATE	APPROVED
A	CORRECTED FRAME SIDE VIEW DIMENSIONS, SHEET 1	9/27/2022	CDL



 ALASKA RAILROAD CORPORATION ENGINEERING SERVICES	PROJECT		
	MOTIVE POWER AND EQUIPMENT PASSENGER COACHES		
	TITLE		
	ARR 301 SINGLE SEAT FRAME FRAME ASSEMBLY		
APPROVED	ARRC	SCALE	SHEET 4/4
CHECKED	ARRC	DATE	
DRAWN	CDL	9/13/2022	

