

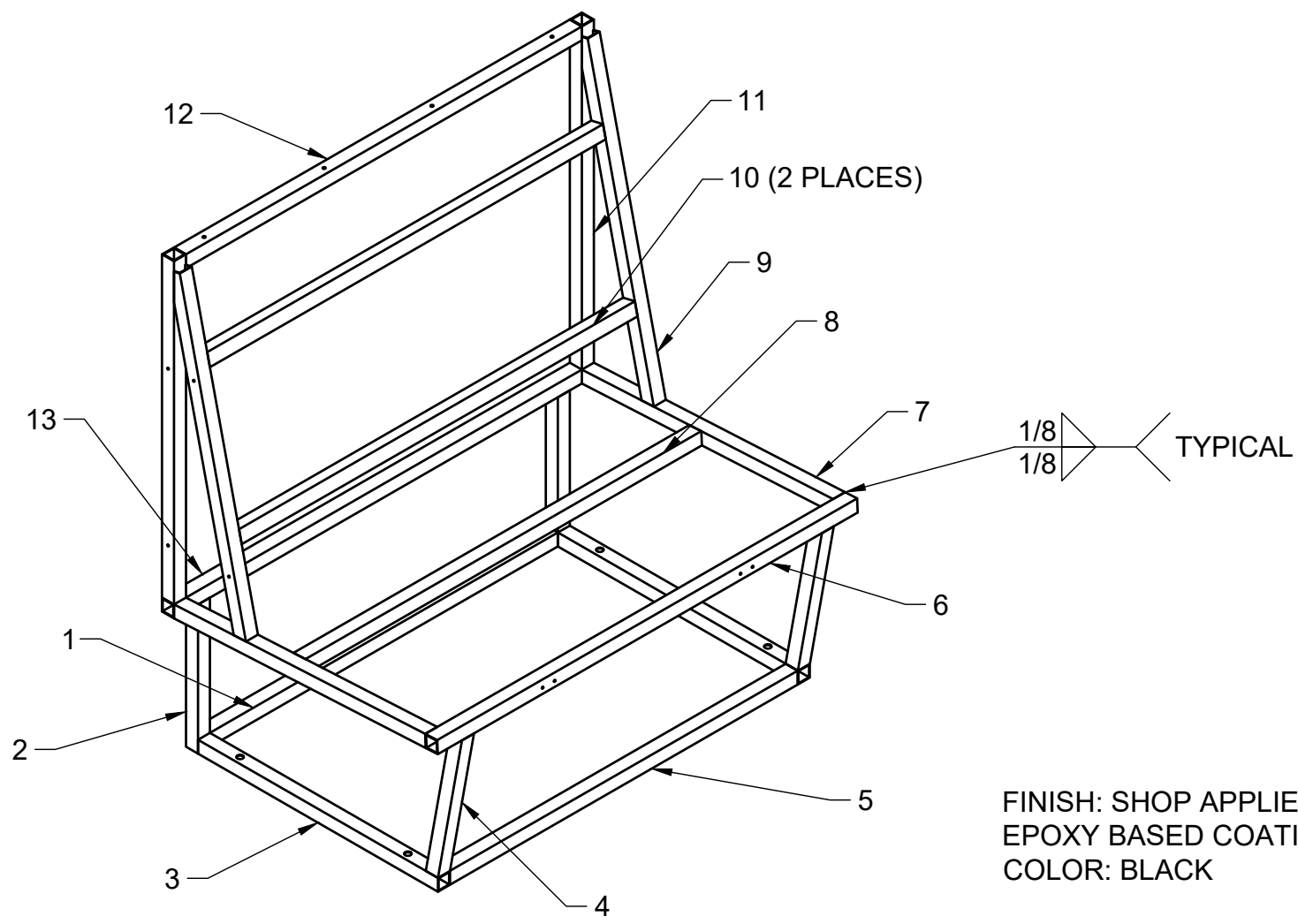

ARR 352 SINGLE SEAT FRAME BOM		
ITEM	QTY	DESCRIPTION
1	1	1"x0.0625" A36 MILD STEEL TUBE, 29" LONG
2	2	1"x0.0625" A36 MILD STEEL TUBE, 10.75" LONG
3	2	1"x0.0625" A36 MILD STEEL TUBE, 20" LONG, SEE SHEET 2
4	2	1"x0.0625" A36 MILD STEEL TUBE, SEE SHEET 2
5	1	1"x0.0625" A36 MILD STEEL TUBE, 29" LONG
6	1	1"x0.0625" A36 MILD STEEL TUBE, 35" LONG, SEE SHEET 2
7	2	1"x0.0625" A36 MILD STEEL TUBE, SEE SHEET 2
8	1	1"x0.0625" A36 MILD STEEL TUBE, 33" LONG
9	2	1"x0.0625" A36 MILD STEEL TUBE, SEE SHEET 2
10	2	1"x0.0625" A36 MILD STEEL TUBE, 33" LONG
11	2	1"x0.0625" A36 MILD STEEL TUBE, 24" LONG, SEE SHEET 2
12	1	1"x0.0625" A36 MILD STEEL TUBE, 33" LONG, SEE SHEET 2
13	1	1"x0.0625" A36 MILD STEEL TUBE, 35" LONG

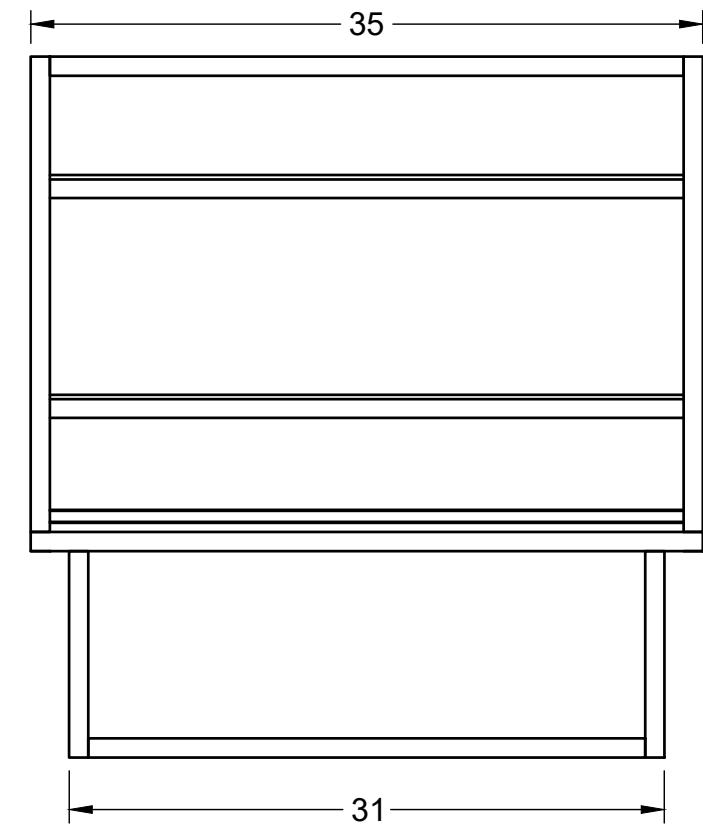

FINISH: SHOP APPLIED EPOXY BASED COATING.
COLOR: BLACK



 ALASKA RAILROAD CORPORATION ENGINEERING SERVICES	PROJECT MOTIVE POWER AND EQUIPMENT PASSENGER COACHES		
	TITLE ARR 352 SINGLE SEAT FRAME FRAME ASSEMBLY		
	APPROVED ARRC	SCALE 1:8	SHEET 1/3
	CHECKED ARRC	DATE 8/10/2022	
DRAWN CDL			

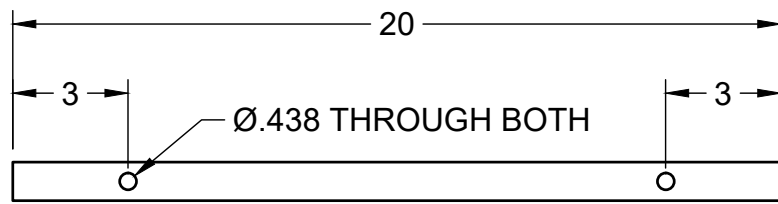

ITEM 3 - TOP VIEW

FROM SHEET: 1
MATERIAL: 1" x 0.065" WALL A36 MILD STEEL TUBE

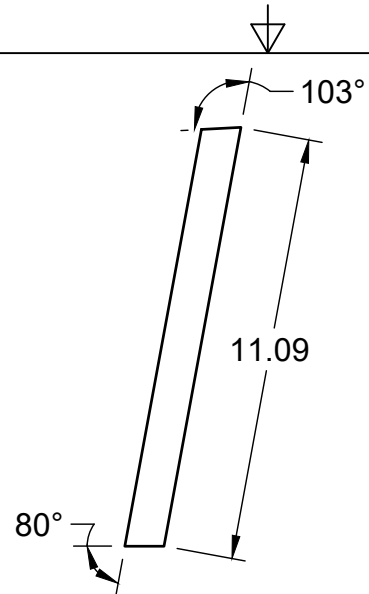

ITEM 4 - SIDE VIEW

FROM SHEET: 1
MATERIAL: 1" x 0.065" WALL A36 MILD STEEL TUBE

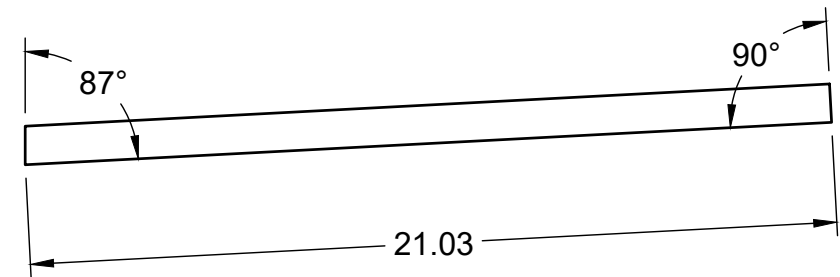

ITEM 7 - SIDE VIEW

FROM SHEET: 1
MATERIAL: 1" x 0.065" WALL A36 MILD STEEL TUBE

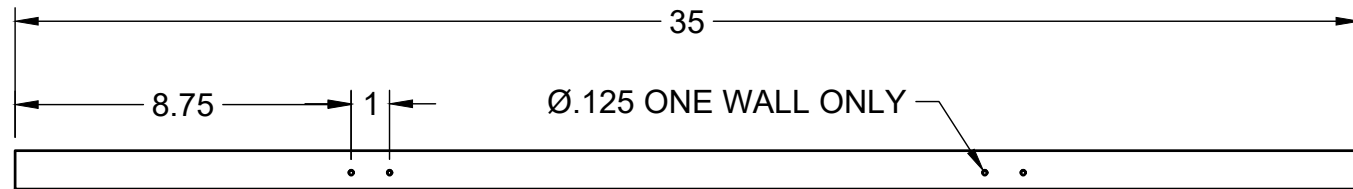

ITEM 6 - TOP VIEW

FROM SHEET: 1
MATERIAL: 1" x 0.065" WALL A36 MILD STEEL TUBE

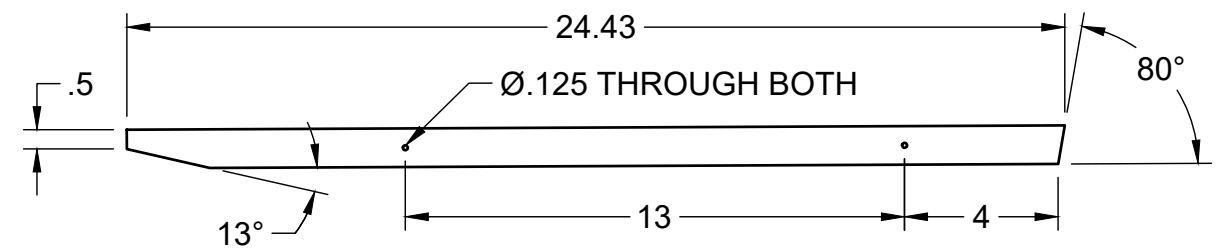

ITEM 9 - ROTATED SIDE VIEW

FROM SHEET: 1
MATERIAL: 1" x 0.065" WALL A36 MILD STEEL TUBE

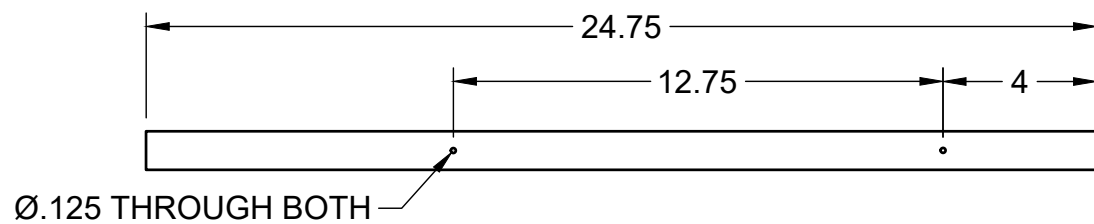

ITEM 11 - ROTATED SIDE VIEW

FROM SHEET: 1
MATERIAL: 1" x 0.065" WALL A36 MILD STEEL TUBE

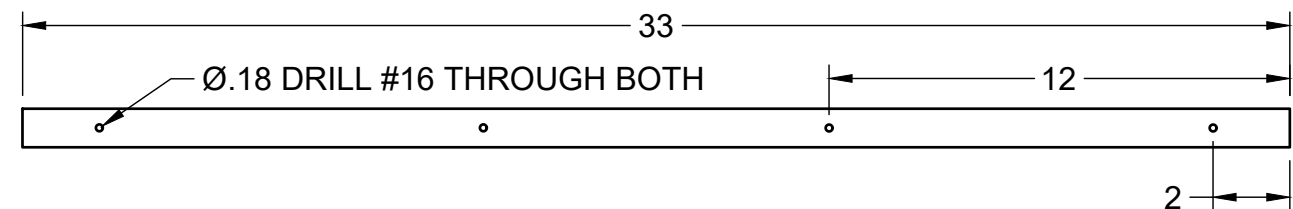

ITEM 12 - TOP VIEW

FROM SHEET: 1
MATERIAL: 1" x 0.065" WALL A36 MILD STEEL TUBE

 ALASKA RAILROAD CORPORATION ENGINEERING SERVICES	PROJECT MOTIVE POWER AND EQUIPMENT PASSENGER COACHES		
	TITLE ARR 352 SINGLE SEAT FRAME ITEM FABRICATION DETAILS		
	APPROVED ARRC	SCALE 1:5	SHEET 2/3
	CHECKED ARRC	DATE 8/10/2022	
DRAWN CDL			

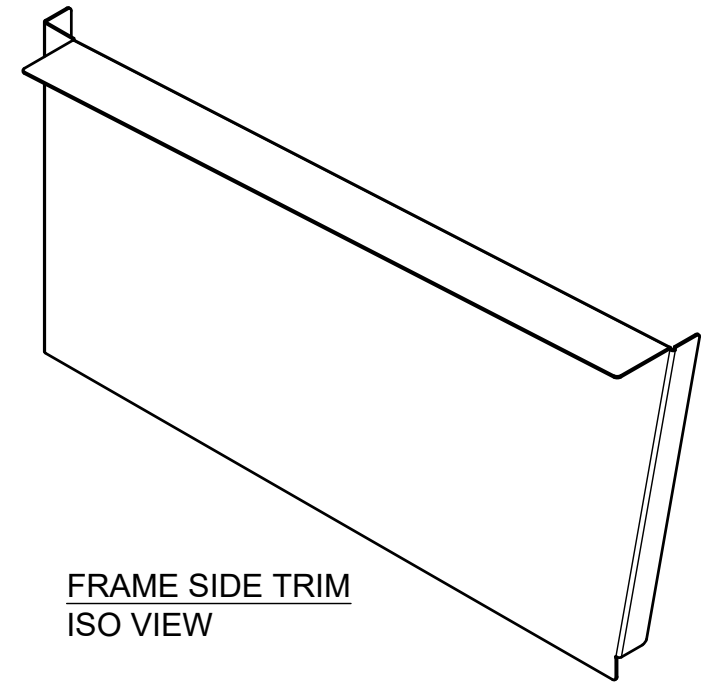
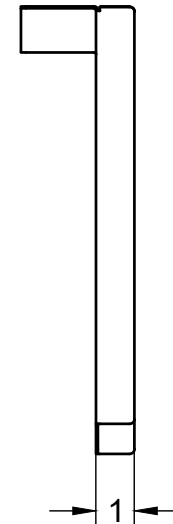
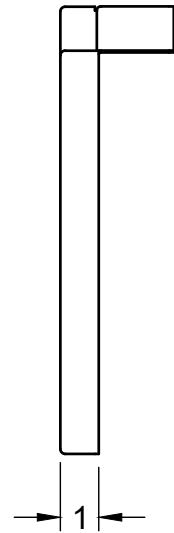
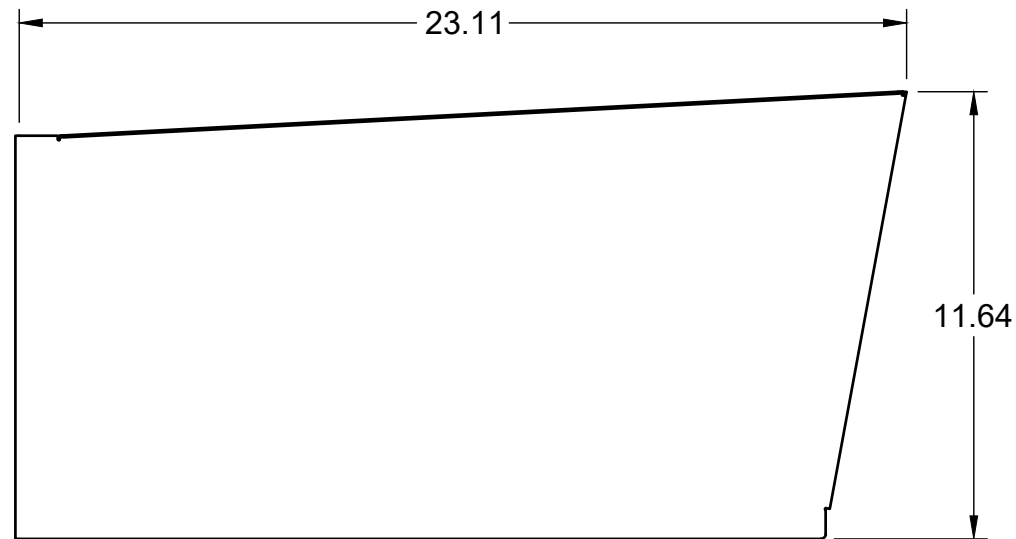
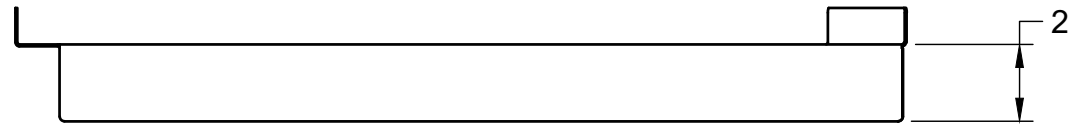

FRAME SIDE TRIM
ISO VIEW

SINGLE SEAT FRAME RIGHT SIDE TRIM

MATERIAL: 18GA 304 SS #4 BRUSH FINISH
 PN ARR-352-0001
 SEE DXF FILE FOR FLAT PATTERN SHAPE
 QTY (1) PER ASSEMBLY

NOTE: PN ARR-352-0002 'SINGLE SEAT FRAME
 LEFT SIDE TRIM' IS MIRROR IMAGE OF RIGHT
 SIDE TRIM.



ALASKA RAILROAD
 CORPORATION
 ENGINEERING SERVICES

PROJECT			MOTIVE POWER AND EQUIPMENT PASSENGER COACHES
TITLE			ARR 352 SINGLE SEAT FRAME TRIM
APPROVED	ARRC	SCALE	1:5
CHECKED	ARRC	DATE	8/10/2022
DRAWN	CDL	SHEET 3/3	